

Modular Cooking Range Line thermaline 90 - 1000 mm Electric Free- cooking Top with Smooth Plate, 1 Side

ITEM # _____

MODEL # _____

NAME # _____

SIS # _____

AIA # _____

589130 (MCTCAAJOAO)

 Electric Free-Cooking Top,
 one-side operated

Short Form Specification

Item No.

Unit constructed according to DIN 18860_2 with 20 mm drop nose top. Internal frame for heavy duty sturdiness in stainless steel. 2 mm top in 1.4301 (AISI 304). Flat surface construction, easily cleanable. THERMODUL connection system enables seamless worktop when units are connected and avoids soil penetrating. Smooth electrically-heated solid plate made of 20 mm thick steel with a wide rounded cleaning zone around the plate. Rapid plate heat up, continuously ready to use; maximum reachable surface temperature of 350°C. Overheat protection switches off the supply in case of overheating. Standby function saves energy and quickly recovers maximum power. Metal knobs with embedded hygienic silicon "soft" grip enable easier handling and cleaning.

IPX5 water resistance certification.

Configuration: One-side operated top. The base needs to be supplied by the factory. Please include appropriate base.

Main Features

- Overheat protection: the temperature sensor switches off the supply in case of overheating.
- All major components may be easily accessed from the front.
- THERMODUL connection system creates a seamless work top when units are connected to each other thus avoiding soil penetrating vital components and facilitating the removal of units in case of replacement or service.
- Metal knobs with embedded hygienic "soft-touch" grip for easier handling and cleaning. The special design of the controls prevents infiltration of liquids or soil into vital components.
- Rapid heat up of the plate and continuously ready for use.
- Wide rounded cleaning zone around the plates for easier cleaning.
- Cooking plate and base joint profile guarantee against soil infiltration.
- Surface temperature up to 350°C
- Large visible digital display manufactured in tempered glass to resist heat and chemicals, showing temperatures or power settings. The display also shows on/off status of the appliance and on/off status of the heating elements.
- For direct and indirect cooking.

Construction

- Unit constructed according to DIN 18860_2 with 20 mm drop nose top and 70 mm recessed plinth.
- IPX5 water resistance certification.
- Flat surface construction with minimal hidden areas to easily clean all surfaces
- Internal frame for heavy duty sturdiness in 1.4301 (AISI 304).
- Unit constructed according to DIN 18860_2 with 20 mm drop nose top.
- Cooking surface is an electrically heated solid plate made from 20 mm thick stainless steel AISI 316 - DIN 1.4404.
- 2mm thick top in stainless steel AISI 304 - DIN 1.4301.

Sustainability

- Standby function for energy saving and fast recovery of maximum power.

Optional Accessories

- Portioning shelf, 1000mm width PNC 912528
- Portioning shelf, 1000mm width PNC 912558
- Folding shelf, 300x900mm PNC 912581
- Folding shelf, 400x900mm PNC 912582
- Fixed side shelf, 200x900mm PNC 912589
- Fixed side shelf, 300x900mm PNC 912590
- Fixed side shelf, 400x900mm PNC 912591
- Endrail kit, flush-fitting, left PNC 913111
- Endrail kit, flush-fitting, right PNC 913112

APPROVAL: _____

- Scraper for smooth plates PNC 913119
- Endrail kit (12.5mm) for thermaline 90 units, left PNC 913202
- Endrail kit (12.5mm) for thermaline 90 units, right PNC 913203
- T-connection rail for back-to-back installations without backsplash (to be ordered as S-code) PNC 913227
- Insert profile d=900 PNC 913232
- Energy optimizer kit 40A - factory fitted PNC 913248
- Endrail kit, (12.5mm), for back-to-back installation, left PNC 913251
- Endrail kit, (12.5mm), for back-to-back installation, right PNC 913252
- Endrail kit, flush-fitting, for back-to-back installation, left PNC 913255
- Endrail kit, flush-fitting, for back-to-back installation, right PNC 913256
- Filter W=1000mm PNC 913666
- Electric mainswitch 63A 10mm² NM for modular H800 electric units (factory fitted) PNC 913677

Recommended Detergents

- C41 HI-TEMP RAPID DEGREASER, 1 pack of six 1 lt. bottles (trigger incl.) PNC 0S2292

Front

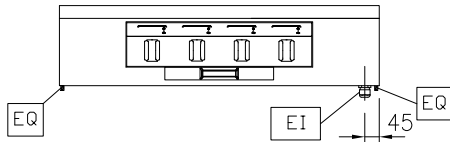

Side

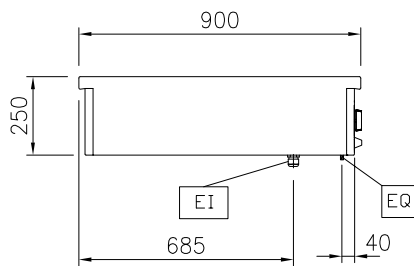
 EI = Electrical inlet (power)
 EQ = Equipotential screw

Top

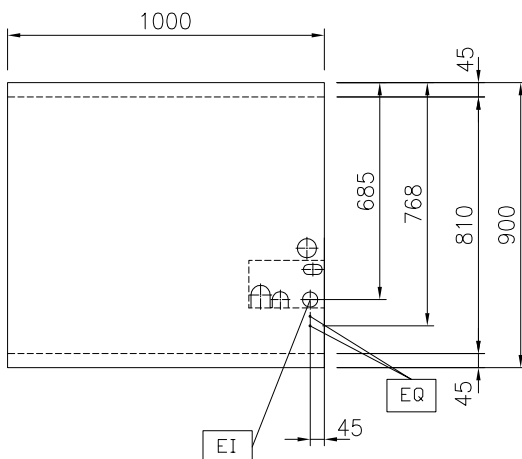

Electric

Supply voltage: 400 V/3N ph/50/60 Hz
 Total Watts: 16 kW

Key Information:

Working Temperature MIN: 80 °C
 Working Temperature MAX: 350 °C
 External dimensions, Width: 1000 mm
 External dimensions, Depth: 900 mm
 External dimensions, Height: 250 mm
 Net weight: 160 kg
 Configuration: One-Side Operated;Top

Sustainability

Current consumption: 34.8 Amps